

Name: _____ Date: _____ Event: _____

Track: Indoor Outdoor Size: Small Medium Large Traction: Low Med High

Surface: Smooth Bumpy Rutted Type: Loose/Loamy Hard Pack Blue Groove Clay

Condition: Dusty Dry Wet Muddy

Bumpsteer/Ackerman/Servo Saver:

washers over # washers under #

ballstud orientation

front middle rear

Front End:

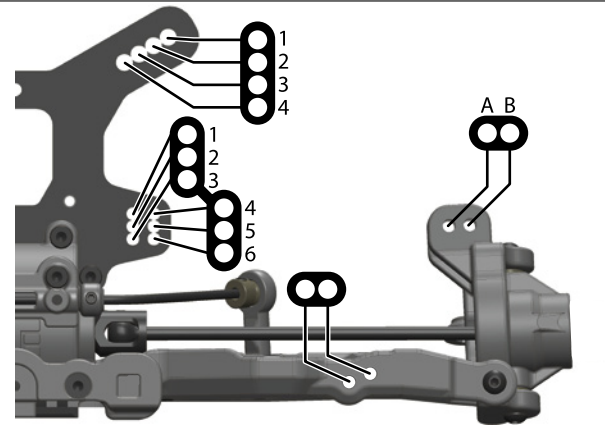

"A" Block
(0° WITH CENTER DOT INSERT)
Composite Aluminum

(Sweep)

"B" Block
(10° WITH CENTER DOT INSERT)
Composite Aluminum

(Kick Up)

Rear End:

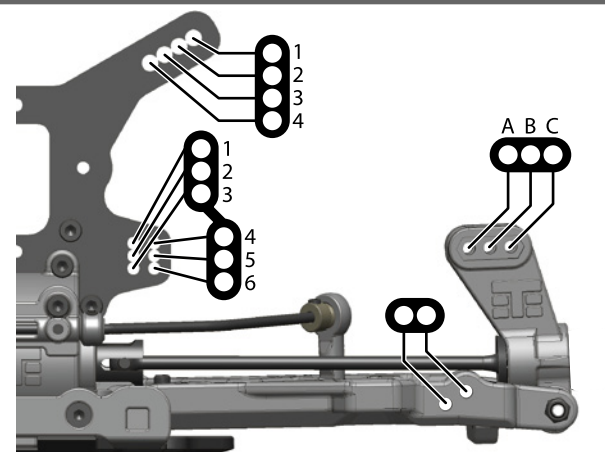

"C" Block
(3° WITH CENTER DOT INSERT)
Composite Aluminum (-1°)

(Anti-Squat)

"D" Block
(3° WITH CENTER DOT INSERT)
Composite Aluminum

(Rear Toe)

Turns from fully tight

of washers

Suspension:

	FRONT	REAR
RIDE HEIGHT		
CAMBER		
CASTER		
SWEEP		
KICK UP		
ANTI-SQUAT		
TOE (in/out)		
SWAY BAR		
SHOCK LENGTH (DROOP)		

Body/Mounts:

BODY MAKE	
-----------	--

Front (Height)

Rear (Height)

Wheelbase:

large 2mm

small 1mm

mm /FRONT

mm /REAR

Shocks:

	FRONT	REAR
OIL		
BRAND		
PISTON		
SPRING		
REBOUND	%	%
STD/EMUL/VENT		

NOTES:

Tires/Wheels:

	FRONT	REAR
BRAND/TREAD		
COMPOUND		
INSERT		
WHEEL		

NOTES:

Differential Oil:

FRONT	CENTER	REAR

Electronics:

ESC:	
Battery:	
Motor:	
Radio:	
Servo:	

Drivetrain:

PINION SIZE		(teeth)
-------------	--	---------

Chassis Braces:

Front <input type="checkbox"/>	Middle <input type="checkbox"/>	Rear <input type="checkbox"/>
(front brace is always recommended)		

Notes:
