

Front Suspension:

Ride Height: _____

Camber: _____

Toe: _____

Anti-Roll Bar

Size: _____

Gap: _____

Ackerman

Notes: _____

Drive Shaft: CVAs: Universals:

Chassis Brace: Short: Long:

Hex: _____

Notes: _____

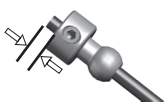

Caster Shim: _____

Upper Ball Type: _____

Upper Ball Shim: _____

Washers: _____

Lower Ball Shim: _____

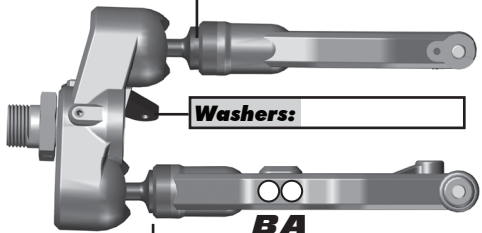
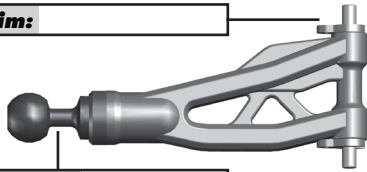

Wheelbase Shim: _____

Lower Ball Type: _____

Upper Arm Mount: _____

Arm Mount A: _____

Arm Mount B: _____

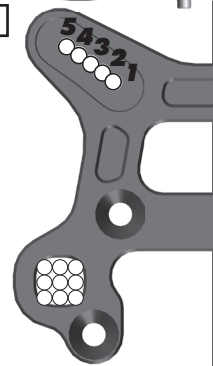
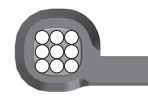
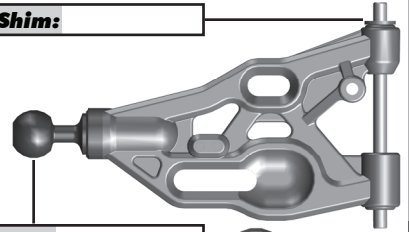

Rear Suspension:

Ride Height: _____

Camber: _____

Anti-Roll Bar

Size: _____

Gap: _____

Drive Shaft: CVAs: Universals:

Chassis Brace: Short: Long:

Hex: _____

Notes: _____

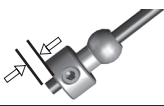

Hub Shim: _____

Wheelbase Shim: _____

Arm Mount C: _____

Arm Mount D: _____

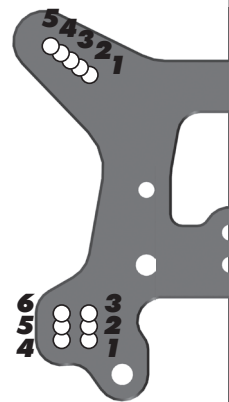
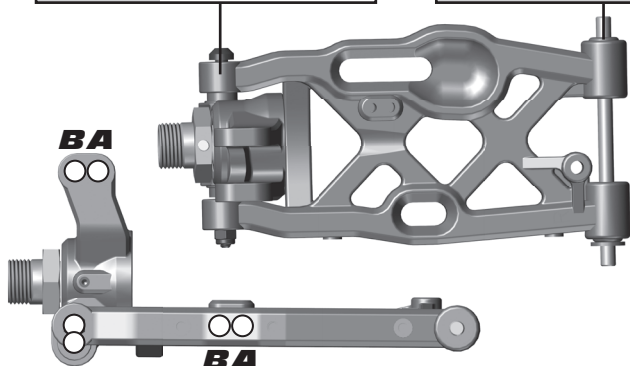

Electronics:

Radio: _____

Servo: _____

EPA: Throttle: _____ % Brake: _____ %

EXPO: Throttle: _____ % Brake: _____ %

ESC: _____

Motor: _____

Battery: _____

Notes: _____

Differential:

	Fluid	Gear Set	Planet O-Rings
Front:			
Center:			
Rear:			

Gearing:

Spur Gear: _____ **Pinion:** _____

Notes: _____

Shocks:

	Front	Rear
Piston:		
Fluid:		
Cap:		
Rebound:		
Spring:		
Free Length:		
Notes:		

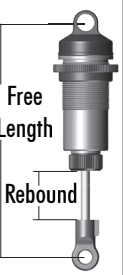

Track Info:

Size: Small Medium Large Extra Large

Surface: Dirt Carpet Astroturf Multi Surface

Traction: Low Medium High Very High

Moisture: Dry Damp Wet

Condition: Indoor Outdoor Dusty Hard Packed
 Bumpy Grooved Smooth Loamy

Temperature: Ambient: _____ Track: _____

Notes: _____

Tires:

Front Tires: _____

Front Compound: _____

Front Insert: _____

Rear Tires: _____

Rear Compound: _____

Rear Insert: _____

Wheel (F/R): _____

Notes: _____

Body, Wings:

Body: _____

Wing: _____

Wing Height: High: Low:

Gap to Tower: _____

Weight:

Total Vehicle Weight: _____

Notes: _____

Vehicle Comments:

Notes: _____