

Front Suspension

Ride Height: _____
 Camber: _____
 Toe: _____
 Anti-Roll Bar: _____
 Wheelbase Shim: _____
 Wheel Hex: _____
 Caster Block: _____

Axle Height:

+3
 +2
 +1
 0

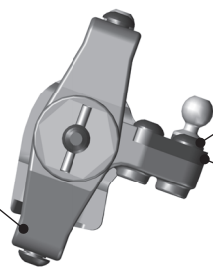

Bump Steer Spacing: _____

Ball Stud Spacing: _____

Steering Plate: _____

Arm Mount A:

LRC HRC 1° 0.5°

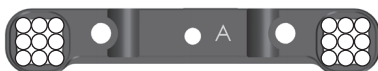

Arm Mount B:

LRC HRC 1° 0.5°



Ball Stud Spacing: _____

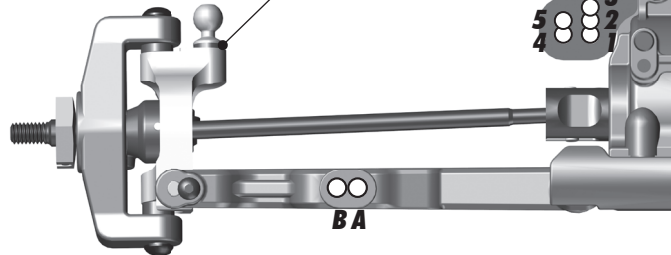

Notes

Rear Suspension

Ride Height: _____
 Camber: _____
 Anti-Roll Bar: _____
 Wheel Hex: _____
 Hub Spacing: Forward Middle Back
 Arm Spacing: Forward Back
 Gearbox Shim: Yes No
 Chassis Brace: Short Long

Arm Mount C:

LRC HRC 1° 0.5°



Arm Mount D:

LRC HRC 1° 0.5°



Rear Hub Link Setting:



Ball Stud Spacing:

Spacing: _____

Hub Insert:

0 (0/3↑)
 +1 (1/2↑)
 +2 (1/2↓)
 +3 (0/3↓)

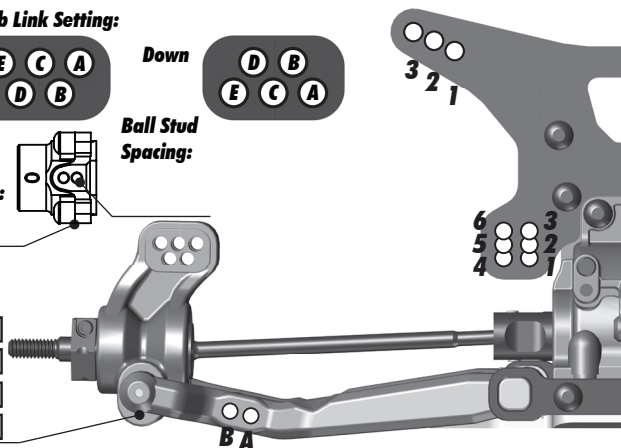

Notes

Track Info, Tires & Aero Electronics, Drivetrain & Shocks

Radio: _____ **Servo:** _____
EPA: Throttle: _____ % Brake: _____ %
ESC: _____
ESC Settings: _____
Motor: _____ **Timing:** _____
Pinion: _____ **Spur:** _____
Battery: _____
Battery Position: _____

Front Fluid: _____
Gears: Plastic Metal
Center Fluid: _____
Gears: Plastic Metal
Rear Fluid: _____
Gears: Plastic Metal
Slipper Clutch: _____
of Pads: _____

Shocks:	Front	Rear
	Piston:	
Fluid:		
Spring:		
Limiters:		
Stroke:		
Eyelet Length:		
Cup Offset:		
Notes:		



Size: Small Medium Large Extra Large
Surface: Dirt Carpet Astroturf Multi Surface
Traction: Low Medium High Very High
Moisture: Dry Damp Wet
Condition: Indoor Outdoor Dusty Hard Packed
 Bumpy Grooved Smooth Loamy
Temperature: Ambient: _____ Humidity: _____
Notes: _____

Front Tires: _____
Front Compound: _____
Front Insert: _____
Rear Tires: _____
Rear Compound: _____
Rear Insert: _____
Wheel (F/R): _____
Notes: _____

Body: _____
Wing: _____
Wing Angle: 0° 3° 6°
Chassis Weights: _____
 None 15g 30g Other
Other Weights: _____
Total Vehicle Weight: _____

Comments
