

### Front Suspension:

### Reset Forms

Ride Height: 17mm  
 Camber: -1°  
 Toe: Full droop, slight toe out  
 Anti-Roll Bar: None  
 Arm Type: #92410, Kit  
 Tower Type: #92430, kit  
 Wheel Hex: #91682, 5mm (Kit)  
 Steering Block KPI: #92414, -4 trailing / 2 kpi (kit)  
 Caster Block Insert: 0  +2.5  +5   
 Bulkhead Type: Alu  
 Kick-Up Angle: -2.5  0  +2.5   
 Steering Stop Spacing: Remove Screw  
 Caster Block Spacing: Fwd  Back   
 Notes: #91983 FT Steering Bellcranks, Aluminum

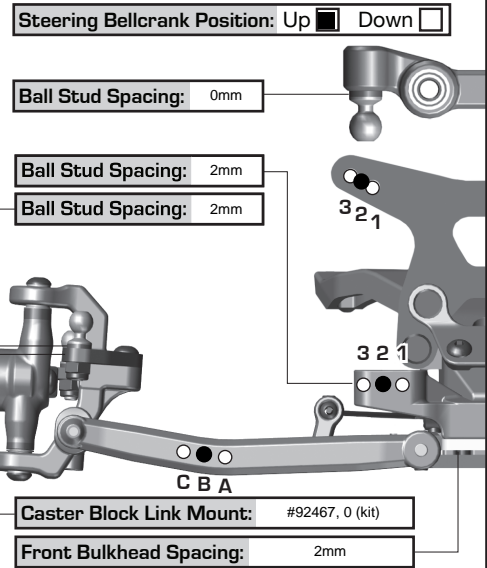
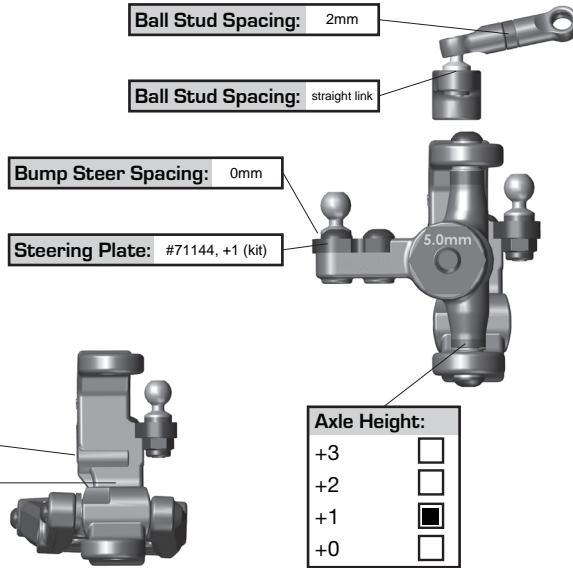

Axle Height:  
 +3   
 +2   
 +1   
 +0

Caster Block Link Mount: #92467, 0 (kit)  
 Front Bulkhead Spacing: 2mm

### Rear Suspension:

Ride Height: 17mm  
 Camber: -1  
 Anti-Roll Bar: None  
 Arm Type: #92408 (kit)  
 Tower Type: #92431 (kit)  
 Arm Spacing: Fwd  Mid  Back   
 Wheel Hex: #91609 FT, Clamping, 5mm (kit)  
 Hub Type: Std  HRC  #92412 (kit)  
 Hub Spacing: Fwd  Mid  Back   
 Drive Shaft: CVA's  Universals   
 Notes: Lube cva joints with 1up red

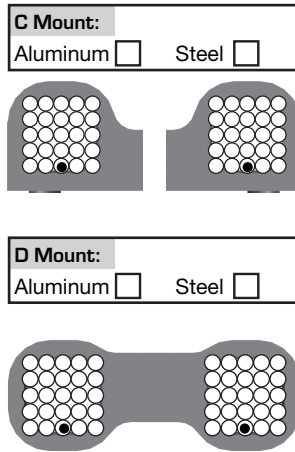

Axle Height:  
 ▼0 3▲ +3  
 ▼1 2▲ +2  
 ▲1 2▼ +1  
 ▲0 3▼ +0

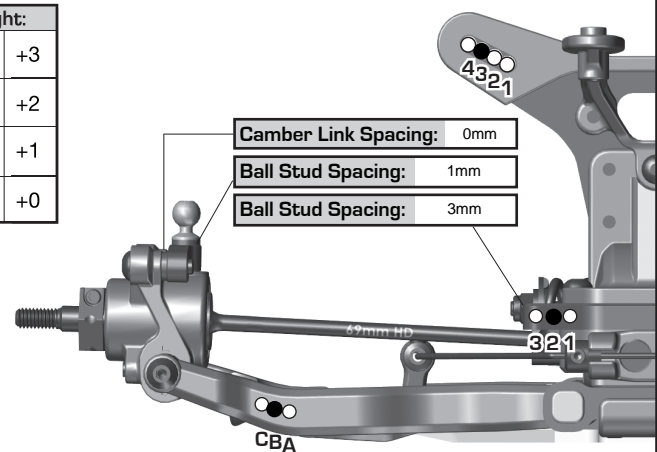

### Electronics:

Radio: Noble NB4 Servo: Savox 1258tg  
 EPA: Throttle: 90 % Brake: 80 %  
 ESC: Reedy 510r  
 ESC Settings: N/A  
 Motor / Wind: Reedy M4 7.5 Timing: N/A  
 Pinion: 20t Spur: 78t  
 Battery Mount: Std  Offset   
 Battery: Reedy LP 4800 Weight: None  
 Notes: look at me being all unsponsored and running what i have

### Drivetrain:

Differential: Ball Diff:   
 Height: 1 Gear Diff:   
 Diff Setting: medium - tight  
 Notes: built with 1up pink / gold  
**Slipper Clutch:**  
 Type: #92451, #91803 (kit)  
 # of Pads: 2x19mm  
 Setting: Car pops wheelies at 85% throttle  
 Notes:

### Shocks:

	Front	Rear
Piston:	1.8+1.7	2x1.9 + 1
Thickness:	2.5mm	2.5mm
Fluid:	30wt	25wt
Spring:	1up X-Gear Yellow	AE White
Limiters:	Int: 0mm Ext: 0mm	Int: 0mm Ext: 2mm
Stroke:	23mm	28.5mm
Eyelet:	+2mm	+4mm
Cup Offset:	0 <input type="checkbox"/> +5 <input checked="" type="checkbox"/> +9 <input type="checkbox"/>	0 <input type="checkbox"/> +5 <input type="checkbox"/> +9 <input type="checkbox"/>
Kashima Bodies:	<input type="checkbox"/>	Chrome Shafts: <input type="checkbox"/> Machined Spacers: <input type="checkbox"/>
Notes:	built with tdk shock assembly grease	

### Track Info:

Size: medium small  
 Surface: Dirt (Packed)  
 Traction: medium-high / high  
 Moisture:  
 Condition: blown off  
 Temperature:  
 Notes:

### Tires:

Front Tires: Smoothie 2s  
 Front Compound: Silver  
 Front Insert: Dirt-Tech  
 Rear Tires: Smoothie 2s  
 Rear Compound: Silver  
 Rear Insert: Dirt-Tech  
 Wheel (F/R): JC mono  
 Notes: tdk edge / gen 2 (5 min timer) then wipe

### Body, Weight:

Body: #92422 B7 Body  
 Front Wing: No  
 Rear Wing: #JCO0503 High Clearance Wing  
 Wing Angle: 0°  3°  6°   
 Chassis Length: #92400, B7 Chassis (kit)  
 Servo Weights: None  
 Electronic Weights: #91976, alu, 11g (kit)  
 Total Vehicle Weight:

### Vehicle Comments:

Notes: JC #51361 Fin Titanium Turnbuckle (Burnt Blue)