

Front Suspension:

Reset Forms

Ride Height: 17mm

Camber: -1°

Toe: Full droop, slight toe out

Anti-Roll Bar: None

Arm Type: #92410, Kit

Tower Type: #92430, kit

Wheel Hex: #91682, 5mm (Kit)

Steering Block KPI: #92414, -4 trailing / 2 kpi (kit)

Caster Block Insert: 0 +2.5 +5

Bulkhead Type: #92436 FT, Aluminum. 0°

Kick-Up Angle: -2.5 0 +2.5

Steering Stop Spacing: Remove Screw

Caster Block Spacing: Fwd Back

Notes: add horn shims until link is straight
#91983, FT Steering Bellcranks, Aluminum

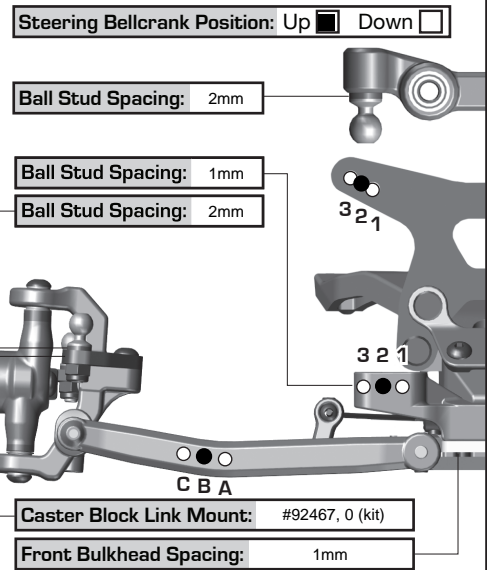
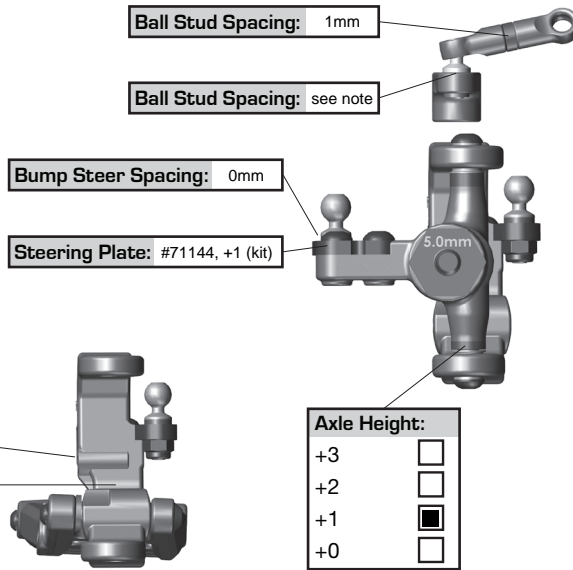

Rear Suspension:

Ride Height: 17mm

Camber: -1

Anti-Roll Bar: None

Arm Type: #92408 (kit)

Tower Type: #92431 (kit)

Arm Spacing: Fwd Mid Back

Wheel Hex: #91609 FT, Clamping, 5mm (kit)

Hub Type: Std HRC #92412 (kit)

Hub Spacing: Fwd Mid Back

Drive Shaft: CVA's Universals

Notes:

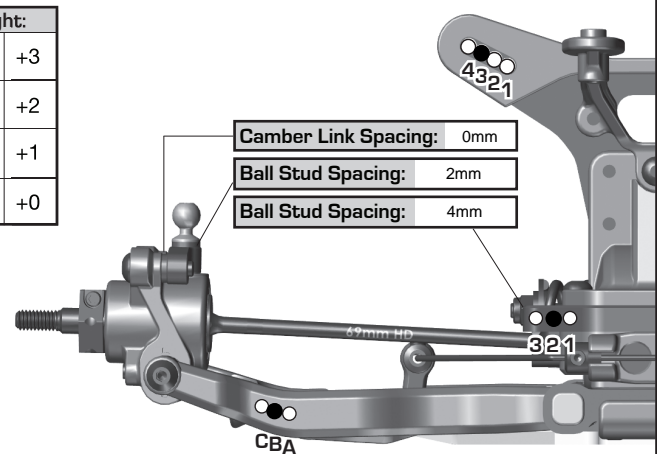
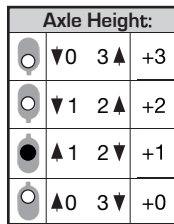
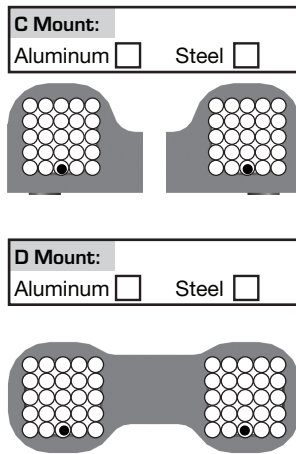

Electronics:

Radio: Noble NB4 **Servo:** Savox 1258tg

EPA: Throttle: 100 % Brake: 100 %

ESC: Reedy 510r

ESC Settings:

Motor / Wind: MC4 17.5 **Timing:** 46.5

Pinion: 32t **Spur:** 72t

Battery Mount: Std Offset

Back 1 2 3 4 5 Forward

Battery: Reed Zap 6400 **Weight:** None

Notes: being sponsored is weird. running whatever is cool

Drivetrain:

Differential: Ball Diff:

Height: 1 **Gear Diff:**

Diff Setting: yes

Notes: built with ae kit oils

Slipper Clutch:

Type: #92451, #91803 (kit)

of Pads: 2x19mm

Setting: tighten slipper until it slips, its stock

Notes:

Shocks:

	Front	Rear
Piston:	2x1.5 + 1.6	3x1.7
Thickness:	2.5mm	2.5
Fluid:	30wt	27.5wt
Spring:	1up red	1up gold
Limiters:	Int: 0 Ext: 0	Int: 0 Ext: 0
Stroke:	23	28
Eyelet:	2	4
Cup Offset:	0 <input type="checkbox"/> +5 <input checked="" type="checkbox"/> +9 <input type="checkbox"/> 0 <input type="checkbox"/> +5 <input type="checkbox"/> +9 <input type="checkbox"/>	
Kashima Bodies:	<input type="checkbox"/>	<input type="checkbox"/>
Chrome Shafts:	<input type="checkbox"/>	<input type="checkbox"/>
Machined Spacers:	<input type="checkbox"/>	<input type="checkbox"/>

Notes:

Track Info:

Size: Small

Surface: Natural Dirt (Packed)

Traction: High

Moisture:

Condition: blown off

Temperature:

Notes:

Tires:

Front Tires: Smoothie 2s

Front Compound: Silver

Front Insert: Dirt-Tech

Rear Tires: Smoothie 2s

Rear Compound: Silver

Rear Insert: Dirt-Tech

Wheel (F/R): JC mono

Notes: tdk edge sauce 5 min then run

Body, Weight:

Body: #92422 B7 Body

Front Wing: No

Rear Wing: #JCO0503 High Clearance Wing

Wing Angle: 0° 3° 6°

Chassis Length: #92400, B7 Chassis (kit)

Servo Weights: None

Electronic Weights: #91976, alu, 11g (kit)

Total Vehicle Weight:

Vehicle Comments:

Notes: if traction rolling, go down to 16mm, if still rolling, go to the thinnest sway bar in the rear.

i went to 2mm bulkhead shim, havent tested yet

i usually run 1mm but everyone is running 2mm